

## Lo-Carbon Sentinel Kinetic Plus

- Acoustic Enclosure option for reduced breakout noise
- Acoustic Top Box option for reduced in-duct noise
- Recognised in SAP PCDB
- Horizontal duct option for space-saving installations
- High airflow, ideal for student accommodation clusters
- Unique folding filter for removal when access is restricted
- Integrated digital controller for simple and accurate commissioning
- Plug and play controls; Humidistat
- BMS connectivity
- LS inputs (Light Switch)
- Volt-free inputs
- Self diagnosis for simplified fault finding
- Adjustable delay On/delay Off timer
- 4 fully adjustable speeds and a purge setting



CODE	DESCRIPTION
447938	Sentinel Kinetic Plus BS
443028	Sentinel Kinetic Plus Right
479538	Sentinel Kinetic Plus Right with Acoustic Top Box & Enclosure
479537	Sentinel Kinetic Plus Right with Acoustic Top Box
479536	Sentinel Kinetic Plus Right with Acoustic Enclosure
443028L	Sentinel Kinetic Plus Left
479541	Sentinel Kinetic Plus Left with Acoustic Top Box & Enclosure
479540	Sentinel Kinetic Plus Left with Acoustic Top Box
479539	Sentinel Kinetic Plus Left with Acoustic Enclosure
443283	Wired Remote Controller
448356	LED Alarm with 15m cable
447340	Opto-coupler for volt-free BMS connection
403702	ISO 45% Coarse (G3) 2x Filter
444201	ISO ePM10 50% Pollen (M5) 1x Filter
446523	180mm/200mm Spigot Kit (One per pack)
68MP033G	Anti Vibration Mounts
477988	Acoustic Purge Fan
479829	Acoustic Purge Fan XL

### Increased Performance

The Sentinel Kinetic Plus benefits from the latest high efficiency, backward curved impeller design, ensuring the lowest possible energy consumption, ultra quiet operation and an exceptional performance range covering small one bed apartments to the largest of houses.

For scenarios where noise is a critical issue, an Acoustic Enclosure is available to reduce breakout noise and the Acoustic Top Box will reduce in-duct noise at key frequencies.

### Care Homes & Student Accommodation

The Sentinel Kinetic Plus is ideal for larger homes and multiple occupancy units such as care homes and student accommodation. Capable of 400m<sup>3</sup>/hr at 150Pa, the unit can extract from up to ten bathrooms and a communal kitchen while still achieving almost 90% heat recovery. The fully automatic capability of the Kinetic range means that adequate ventilation is always achieved.

The Kinetic's BMS capability is also ideal for those commercial applications where landlords or property managers want to monitor and optimise building performance and maintenance. The Kinetic BMS can provide status information and its self diagnostics can report if any fault is found.

### Spigot Options

Spigots may be re-positioned to give horizontal connection or a combination of vertical and horizontal connection.

Optional 180mm/200mm spigots can simplify connection in commercial installations where larger diameter duct work has been used.

### Quick Change Filter

As many systems are placed within cupboards the unique filter design folds as you remove it to ensure easy access in restricted spaces.

### Integral Humidity Sensor

The integral humidity sensor increases speed in proportion to relative humidity levels, saving energy and reducing noise. The sensor also reacts to small but rapid increases in humidity, even if the normal trigger threshold is not reached. This unique feature ensures adequate ventilation, even for the smallest wet room. The night time relative humidity setback feature suppresses nuisance tripping as humidity gradually increases with falling temperature.

# Group VA - Vent-Axia Products

## SAP PCDB Test Results (Kinetic Plus BS)

	SAP 2009		SAP 2012	
	Thermal Efficiency %	SFP (W/l/s)	Thermal Efficiency %	SFP (W/l/s)
K+1	91	0.51	91	0.42
K+2	91	0.40	91	0.44
K+3	90	0.41	90	0.52
K+4	90	0.45	90	0.63
K+5	90	0.53	90	0.76
K+6	90	0.60	91	0.90
K+7	90	0.70	91	1.05

## SEC Class

Model	SEC Class
Kinetic Plus	A+

## Sound Data (Unit only)

Unit setting	Test mode	Octave band, Hz, dB SWL								SPL dB(A) at 3m	
		63	125	250	500	1k	2k	4k	8k		LwA
20%	Supply	54.4	60.9	50.6	45.9	34.3	23.6	19.1	24.5	51.3	30.8
	Extract	48.4	56.7	43.7	35.9	21.4	16	18.7	24.5	42.3	24.8
	Breakout	42.6	40.2	39.6	38	31.1	24.3	19.4	24.6	35.1	17.6
40%	Supply	61.6	64.6	58.4	55.5	45.9	37.2	24.7	25.1	58.8	38.3
	Extract	54.9	62.2	51.5	44.8	32.1	24.1	19.7	24.6	48.8	31.3
	Breakout	51.1	49.3	48.9	45.9	41.3	35.7	26.7	25.6	44.0	26.5
60%	Supply	67.5	67.5	73.2	62.4	53.4	47.5	33.5	28.3	69.2	48.7
	Extract	62.5	61.7	60.1	51.1	39.2	32.1	23.2	24.8	54.0	36.5
	Breakout	54.9	53	58.4	55.1	49.7	43.9	35.4	31.9	52.8	35.3
80%	Supply	70.5	71.1	73.8	66.5	58.3	53.2	39.7	33.3	71.3	50.8
	Extract	68.4	65.9	71.8	55.6	43.6	37.1	27.3	25.5	63.8	46.3
	Breakout	59.2	56.8	63.6	57.3	54.2	49	41	37.5	56.8	39.3
100%	Supply	72.8	73.1	75.2	70.4	61.6	56.6	44.2	37.6	73.9	53.4
	Extract	71.7	69	71.8	57.4	45.7	39.9	30.9	26.6	64.1	46.6
	Breakout	61.2	58.8	67.9	59.6	56.7	52.2	44.4	41.2	60.1	42.6

## Sound Data (Unit with Acoustic Solution)

Unit setting	Test mode	Octave band, Hz, dB SWL								SPL dB(A) at 3m	
		63	125	250	500	1k	2k	4k	8k		LwA
20%	Supply	55.7	49.2	36.6	23.6	17.4	14.9	17.8	23.3	36.1	18.6
	Extract	51.4	42.4	30.3	20.9	16.8	14.9	17.8	23.3	30.8	13.3
	Breakout	37.4	39.7	30.0	22.7	15.6	14.0	17.9	23.3	28.4	7.9
40%	Supply	59.7	59.7	45.5	32.2	22.2	15.2	17.9	23.3	45.1	27.6
	Extract	54.8	55.0	38.0	26.8	18.1	14.9	17.8	23.3	40.2	22.7
	Breakout	45.7	48.5	39.9	32.8	24.2	17.5	18.0	23.4	36.8	16.3
60%	Supply	66.1	61.9	53.6	41.0	29.8	18.3	18.0	23.3	49.5	32.0
	Extract	60.6	55.9	48.4	34.9	23.8	16.3	17.9	23.3	43.8	26.3
	Breakout	51.1	51.0	52.4	40.9	33.2	26.1	19.7	23.4	44.5	24.0
80%	Supply	70.0	67.6	68.5	48.1	37.9	25.3	19.4	23.6	60.7	43.2
	Extract	65.4	59.7	57.2	41.6	31.3	21.8	19.2	23.4	50.4	32.9
	Breakout	55.6	55.6	57.9	47.9	40.4	34.3	26.1	23.7	51.3	30.8
100%	Supply	72.1	70.1	66.4	51.6	41.9	29.7	21.7	24.0	60.0	42.5
	Extract	68.2	62.4	60.6	45.5	36.0	26.6	21.7	23.6	53.8	36.3
	Breakout	57.6	58.8	63.3	51.0	44.2	38.5	31.0	24.9	56.3	35.8

Tested according to BS EN 13141-7:2010. Breakout quoted spherical. Supply and Extract quoted hemispherical. For in-duct data, end reflections are added based on the spigot size of the unit.

## Dimensions (mm)

### Unit

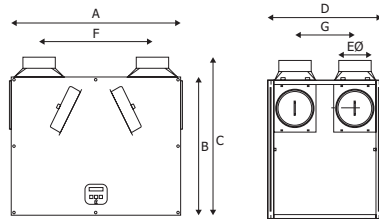

A	B	C	D	EØ	F	G
785	635	722	550	150	520	275

Weight: 24kg

## Acoustic Solution

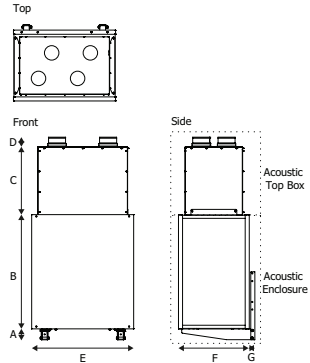

A	B	C	D	E	F	G	Spigot
80	733	501	71	855	583	40	150

Acoustic Top Box 17kg, Acoustic Enclosure 33kg

## Performance

Fan speeds are fully adjustable within the performance range.

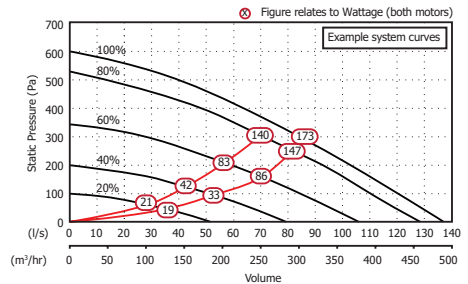

## Consultant's Specification

### Operation

The supply and extract ventilation unit shall be as Sentinel Kinetic Plus as manufactured by Vent-Axia and shall be sized as indicated on the drawings and shall be in accordance with the particular specification.

Supply air to the room shall be pre-heated by the extract air via the integrated composite plastic counterflow heat recovery cell. The Sentinel Kinetic Plus shall automatically vary the ventilation rate via EC/DC motors, as it receives signals from one of the optional interconnected sensors.

When a signal is received, the fans shall either vary their speed proportionally or on a trickle and boost principle.

The unit shall have the facility to commission the supply and extract fans individually via in-built minimum and maximum speed adjustment, or alternative wired remote control unit. The fans themselves shall have independent, infinitely variable speed control.

### Unit Specification

The unit shall be manufactured with an ABS outer case construction, and incorporate a reversible core to allow for left or right hand mounting.

The unit shall have a high efficiency composite plastic counterflow heat exchanger, supply and extract filters, automatic summer bypass, integral minimum and maximum infinitely variable speed controls with fascia mounted failure indication.

The unit shall have low energy, high efficiency EC/DC fan/motor assemblies with sealed for life bearings. The impellers shall be high efficiency backward curved centrifugal type.

The unit shall have a heat exchanger cell with a thermal efficiency of up to 92% when tested to EN 308. This shall be protected by ISO 45% Coarse (G3) grade synthetic filters on supply and extract. Complete with a condensate drip tray and drain connection.

To reduce breakout noise, the MVHR unit shall be provided with an Acoustic Enclosure of steel construction lined with class '0' acoustic foam. To reduce in-duct noise, the top of the MVHR shall be fitted with an Acoustic Top Box to provide attenuation to the 4 ducts of the unit. This Acoustic Top Box shall be of steel construction lined with acoustic class '0' foam with the MVHR spigots linked to the Top Box via 4 separate attenuated ducts. The acoustic enclosure and top box shall each be independently tested for noise to BS EN 13141-7.

The unit shall be constructed with a removable Core allowing full maintenance access. The removable Core shall provide access to the following:

- ✓ Supply and extract filter
- ✓ Heat exchanger
- ✓ Access to the electrical connections

Access shall be provided for wiring termination and setup/commissioning. The backlit LCD user interface therein may be duplicated for remote mounting if required.

Units shall be as manufactured by Vent-Axia Ltd.

The MVHR unit shall incorporate an Expanded Polystyrene (EPS) inner chassis with custom motor and impeller

mounting features. The inner chassis will assist in reducing noise and act as a large anti-vibration mount to avoid transmission through to the back mounting plate or the base of the unit.

The MVHR unit shall be tested to ensure it meets the maximum allowable vibration of no more than 1mm/s, measured on the unit wall fixing points.

Sound tested to BS EN 13141-7:2010

### Standard Controls

All Sentinel Kinetic units shall incorporate the following functions integrally mounted, pre-wired and factory fitted by the manufacturer:

- ✓ Integral infinitely variable fan speed control on supply and extract
- ✓ Integral min/max ventilation control/set point
- ✓ Integral BMS input/output interfaces – control and status indication
- ✓ Heating interlocks
- ✓ 0-10V proportional speed adjustment
- ✓ Volt free contacts
- ✓ 24V sensor supply
- ✓ Integral on/off or trickle boost function from remote switch, e.g. PIR occupancy detector
- ✓ Fully automatic summer bypass
- ✓ Switched Live input with adjustable 'delay-on' feature
- ✓ Fan failure or component failure indicated via individual fault code display
- ✓ Running time counter
- ✓ Control panel PIN number lock
- ✓ Automatic frost protection effective to -20°C
- ✓ The unit shall incorporate an integral humidity sensor with the following features:
  - Ambient Response: Raises the humidity trigger point as dwelling temperature reduces
  - Rapid Response: Monitors the rate of change in humidity and triggers increased airflow even if the humidity trigger threshold is not reached
  - Proportional Response: Incrementally increases the fan speed to reduce noise and reduce energy consumption
- ✓ The unit shall be controlled by the 'Sentinel' control devices (enablers and sensors) as detailed in the schedule or on the drawings.
- ✓ Tool free filter access

### Mounting Option

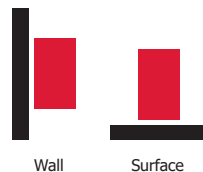

Wall

Surface

## Airflow Direction

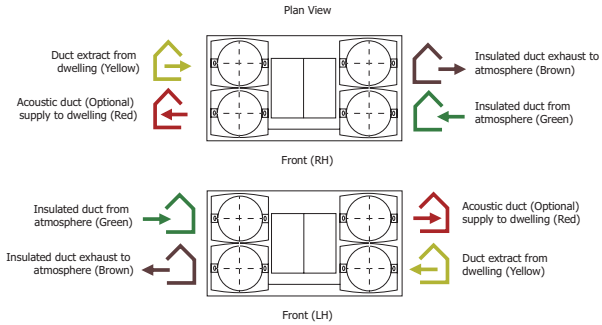

## Electrical Connection

Please note: Electrical connection should be carried out by an appropriately qualified person and in accordance with current wiring regulations.

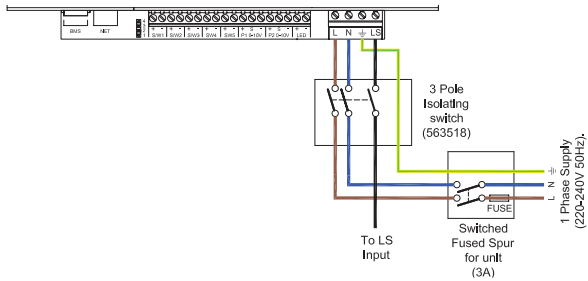

## Trickle to Boost by two lighting circuits or Trickle/Boost Switch

