



## Installation and Wiring Instructions

**MONS100HTA**  
**MONS100PCA**  
**MONS100PIRA**  
**MONS100SA**  
**MONS100TA**  
**MONS125HTA**  
**MONS125SA**  
**MONS125TA**  
**MONS150HTA**  
**MONS150SA**  
**MONS150TA**



**PLEASE READ INSTRUCTIONS IN CONJUNCTION WITH ILLUSTRATIONS.  
PLEASE SAVE THESE INSTRUCTIONS.**

**UK  
CA** **CE** IP45



## Installation and Wiring Instructions for the MONS100/125/150 Range of Extractor Fans.



**IMPORTANT: READ THESE INSTRUCTIONS BEFORE COMMENCING THE INSTALLATION**

DO NOT install this product in areas where the following may be present or occur:

- Excessive oil or a grease laden atmosphere.
- Corrosive or flammable gases, liquids or vapours.
- Ambient temperatures higher than 40°C or less than -5°C.
- Possible obstructions which would hinder the access or removal of the Fan.

### SAFETY AND GUIDANCE NOTES

- A. All wiring to be in accordance with the current I.E.T. Regulations, or the appropriate standards of your country and **MUST** be installed by a suitably qualified person.
- B. The Fan should be provided with a local isolator switch capable of disconnecting all poles, having a contact separation of at least 3mm.
- C. Ensure that the mains supply (Voltage, Frequency, and Phase) complies with the rating label.
- D. The Fan should only be used in conjunction with the appropriate Monsoon products.
- E. The Fan should only be used in conjunction with fixed wiring. Flexible cord must not be used.
- F. Exhaust fans may adversely affect the safe operation of appliances burning gas or other fuels (including those in other rooms) due to back flow of combustion gases. These gases can potentially result in carbon monoxide poisoning. After installation of an exhaust fan such as a partition fan or a duct fan the operation of flued gas appliances should be tested by a competent person to ensure that back flow of combustion gases does not occur.
- G. The Fan should not be used where it is liable to be subject to direct water spray for prolonged periods of time.
- H. Where ducted Fans are used to handle moisture-laden air, a condensation trap should be fitted. Horizontal ducts should be arranged to slope slightly downwards away from the Fan.
- I. This appliance is not intended for use by persons (including children) with reduced physical, sensory or mental capabilities, or lack of experience and knowledge, unless they have been given supervision or instruction concerning use of the appliance by a person responsible for their safety.

- J. Children should be supervised to ensure that they do not play with the appliance.
- K. Stationary appliances not fitted with means for disconnection from the supply mains having a contact separation in all poles that provide full disconnection under over voltage category III, the instructions state that means for disconnection must be incorporated in the fixed wiring in accordance with the wiring rules.
- L. Ensure the grille is fully engaged onto the fan chassis using all 4 clips.

## DESCRIPTION

---

MONS100 axial extract fans are suitable for domestic bathrooms and W.C's. The MONS125 and MONS150 axial extract fans are suitable for domestic kitchens and utility rooms. They are available as wall or panel mounted models with shutter, timer, humidity and PIR combinations.

## INSTALLATION

---

**IMPORTANT:** The fan should only be used in conjunction with fixed wiring.

### PANEL MOUNTING

1. For panel mounting the fan should be installed into a duct protected by an exterior air grille that must comply with the standard requirements of your country to prevent access to the fan's impeller.
2. Cut a 105mm diameter hole for 100mm fans, a 130mm hole for 125mm fans or a 155mm diameter hole for 150mm fans.
3. Push the two clips on the bottom of the fan and pull the grille away from the chassis.
4. Using the built in spirit level bubble as an aid, mark the screw centres through the holes in the fan back plate. Drill, plug and screw into position.
5. After installation, ensure impeller rotates freely and the shutters can open.
6. Replace the grille and ensure the clips engaged.

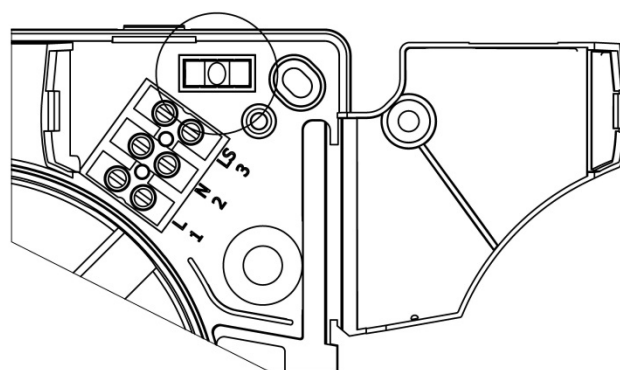
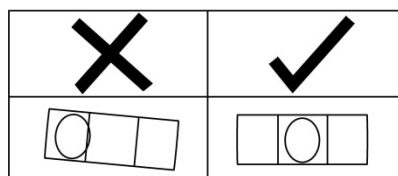

Open up the internal cover to access the spirit level bubble and terminals.

### WALL MOUNTING

1. For wall mounting either cut a 115mm diameter hole for 100mm fans, a 140mm hole for 125mm fans or a 170mm diameter hole for 150mm fans, through the wall and insert the wall sleeve. Slope the sleeve slightly downwards away from the fan. Cut to length and cement both ends into position flush with the wall faces.
2. Push the two clips on the bottom of the fan and pull the grille away from the chassis.
3. Using the built in spirit level bubble as an aid, mark the screw centres through the holes in the fan back plate. Drill, plug and screw into position. Fix exterior grille into position with the louvres positioned downwards. (Note: - The grille must comply with the standard requirements of your country to prevent access to the fan's impeller. The wall kit used in this installation should provide a minimum ducting length of 100mm from the fans back plate to the inside of the external grille).
4. After installation, ensure impeller rotates freely and the shutters can open.
5. Replace the grille and ensure the clips engaged.



**WARNING: THE FAN AND ANCILLARY CONTROL EQUIPMENT MUST BE ISOLATED FROM THE POWER SUPPLY DURING THE INSTALLATION / OR MAINTENANCE.**

### IMPORTANT

- The fan should only be used in conjunction with fixed wiring.
- The cross - sectional area of supply cord used should be ranged from 1 -1.5mm<sup>2</sup>.
- Cable entry can only be made from the rear of the fan.
- The extraction fan is suitable for connection to 220-240V 50Hz supply.
- The fan is a class II double insulated product and **MUST NOT** be earthed.

1. Select and follow the appropriate wiring diagram. (Fig. 1,2 or 3)
2. Check all connections have been made correctly and securely fastened.
3. Ensure the impeller rotates and is free from obstructions.

### SETUP

---



**WARNING: THE FAN AND ANCILLARY CONTROL EQUIPMENT MUST BE ISOLATED FROM THE POWER SUPPLY DURING THE INSTALLATION / OR MAINTENANCE.**

### MONS100S/125S/150S

Single speed fan. Controlled by remote switch (e.g. light switch or auto sensor) Fig.1.

### MONS100PC

Single speed fan. Controlled by the internal pullcord switch Fig.1.

### MONS100T/125T/150T

Single speed with overrun timer. The fan can be wired to a lighting circuit switch. Fig.3. or wired for a basic on/off operation wire as Fig 2.

When switched 'ON', the fan will operate at full speed and will continue to run for a pre-set time after the switch is turned 'OFF'.

#### TIMER ADJUSTMENT

*BEFORE ADJUSTING THE TIMER, SWITCH OFF THE MAINS SUPPLY. TIMER SHOULD ONLY BE ADJUSTED BEFORE OR DURING INSTALLATION.*

1. Remove the fan grille. The controller is factory set at 15 minutes approx. The overrun time period can be adjusted from 5-30 minutes by altering the adjuster on the control PCB. Note the exact min/max time may vary between products.
2. To REDUCE the operating time, use a small screwdriver to turn the adjuster Fig.4. ANTI-CLOCKWISE.
3. To INCREASE the operating time, use a small screwdriver to turn the adjuster Fig.4. CLOCKWISE.
4. Replace the fan grille.

## **MONS100PIR**

Single speed with PIR (passive infra-red) detector and overrun timer. The fan starts automatically when a movement is detected and will continue to operate for the set overrun time period. Fig. 1.

The fan can also be wired to a lighting circuit switch. Fig.3. so it can be started by the light switch or the PIR detector.

### **TIMER ADJUSTMENT**

*BEFORE ADJUSTING THE TIMER, SWITCH OFF THE MAINS SUPPLY. TIMER SHOULD ONLY BE ADJUSTED BEFORE OR DURING INSTALLATION.*

1. Remove the fan grille. The controller is factory set at 15 minutes approx. The overrun time period can be adjusted from 5-30 minutes by altering the adjuster on the control PCB.
2. To **REDUCE** the operating time, use a small screwdriver to turn the adjuster Fig.5. **ANTI-CLOCKWISE**.
3. To **INCREASE** the operating time, use a small screwdriver to turn the adjuster Fig.5. **CLOCKWISE**.
4. Replace the fan grille.

## **MONS100HT/125HT/150HT**

The fan contains an integral humidity controller. In automatic mode the controller switches the fan on at full speed when the room Relative Humidity (RH) increases. The fan will continue to run until the room RH falls.

These fans also include a built in timer function. This gives the fan a fixed over run time of approx. 15 mins. The timer can be deactivated by removing the Jumper JP1, (Fig. 6)

### **HUMIDITY SET-POINT ADJUSTMENT (25-95%RH)**

*BEFORE ADJUSTING THE CONTROLLER, SWITCH OFF THE MAINS SUPPLY. HUMIDISTAT SHOULD ONLY BE ADJUSTED BEFORE OR DURING INSTALLATION.*

1. Remove the fan grille.
2. To **INCREASE SET POINT**, turn the adjuster **clockwise**. This will reduce the internal Relative Humidity set point at which the fan switches on. (Fig. 6)
3. To **REDUCE SET POINT**, turn the adjuster **anti-clockwise**. This will increase the internal Relative Humidity set point at which the fan switches on. (Fig. 6)

The integral pullcord activates the internal 15-minute timer. The timer can be cancelled by pulling the pullcord again. The pullcord can be removed by cutting the cord.

### **COMFORT MODE (HT models only)**

The HT models include Comfort Mode that can be activated via holding the pullcord for 5 seconds. This feature delays the LS input boost operation for a maximum of 20 minutes to reduce noise and cold drafts while bathing. After the LS is disconnected, the fan will switch on for the same period the LS had been active (up to 20 minutes), plus the overrun time period if selected (0 or 15 minutes).

The LED will slowly blink repetitively (every 4 seconds) during comfort mode lead-in time period. The LED transitions from blinking to solid LED on when LS boost is activated.

The fans internal Relative Humidity sensor is disabled during Comfort Mode.

This feature resets if there is a power cut.

### **SPEED SELECTION (HT models only)**

The fan can be set to run on high or low speed depending on the installation requirements.

The fan is factory set to low speed with jumper JP2 fitted. To activate the high speed setting remove jumper JP2. (Fig. 6)



**WARNING: THE FAN AND ANCILLARY CONTROL EQUIPMENT MUST BE ISOLATED FROM THE POWER SUPPLY DURING MAINTENANCE.**

1. At intervals appropriate to the installation, the fan should be inspected and cleaned to ensure there is no build up of dirt or other deposits.
2. Wipe the inlets and front face with a damp cloth until clean.

The fan has sealed for life bearings, which do not require lubrication.

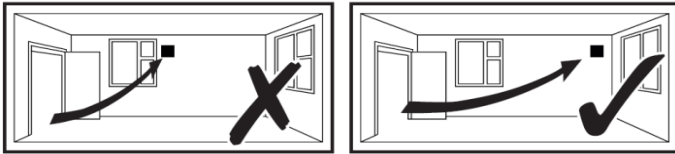

**Fig.1: MONS100S/125S/150S/100PIR/100PC**

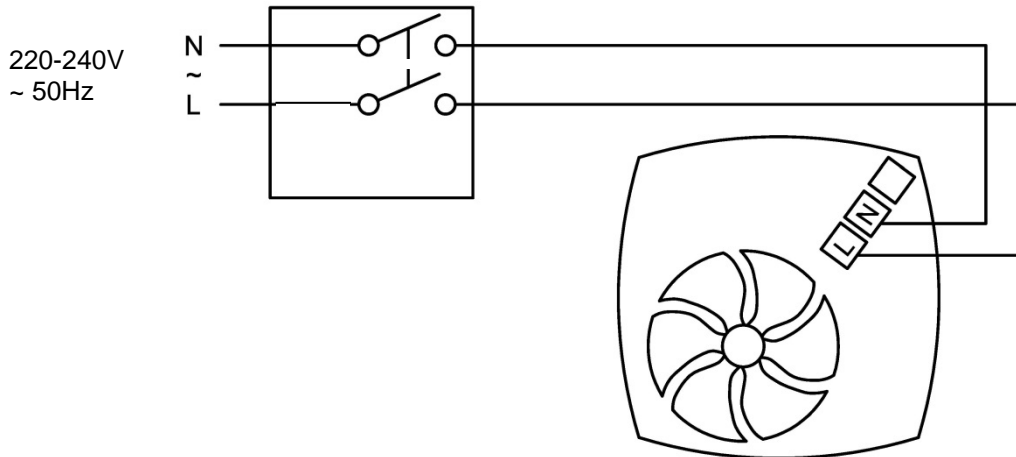

**Fig.2: MONS100T/125T/150T/100HT/125HT/150HT (Timer /Humidistat disabled)**

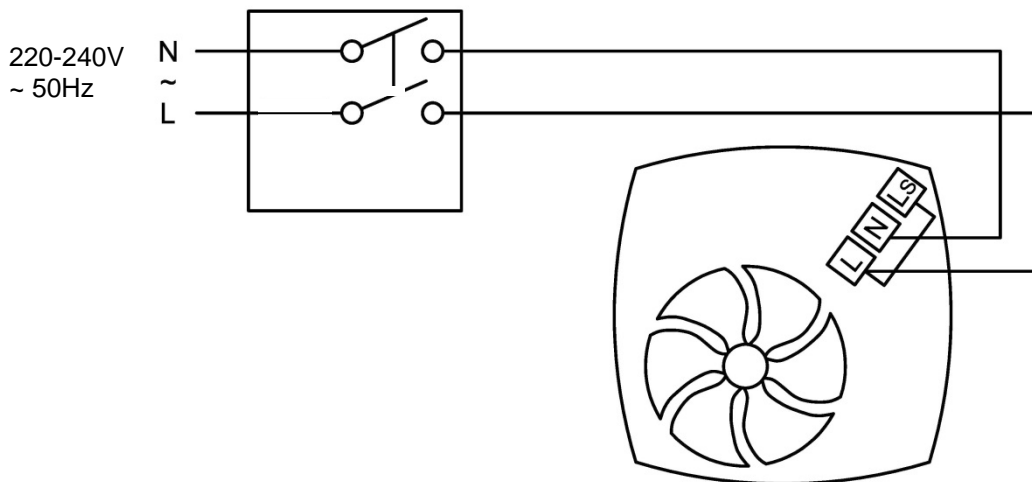

**Fig.3: MONS100T/100PIR/125T/150T/100HT/125HT/150HT**

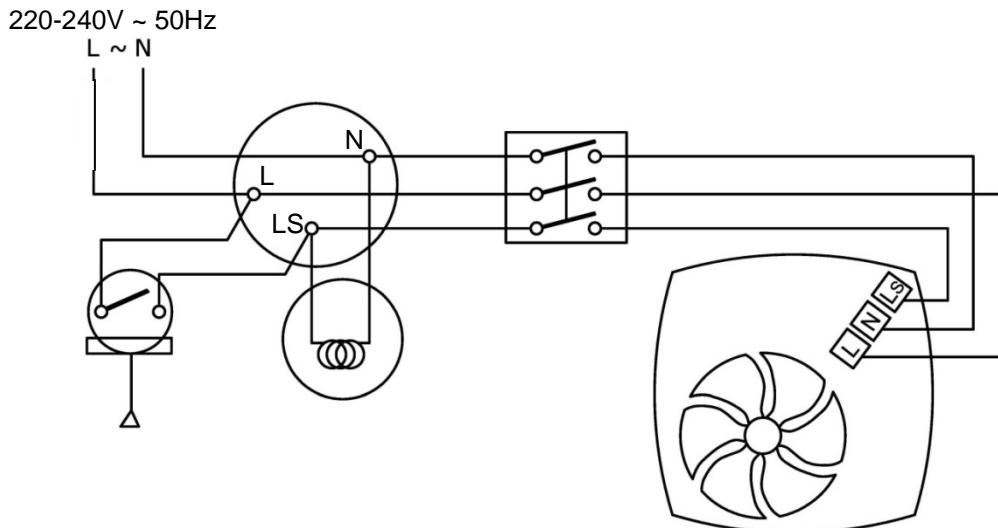

**FIG. 4: TIMER**

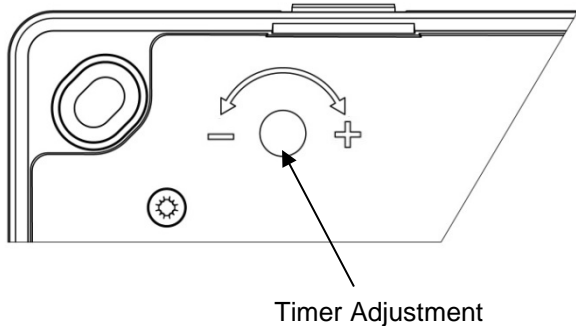

**Timer Adjustment**

To **REDUCE** the operating time, use a small screwdriver to turn the adjuster **ANTI-CLOCKWISE**.  
 To **INCREASE** the operating time, use a small screwdriver to turn the adjuster **CLOCKWISE**.

**FIG. 5: PIR TIMER**

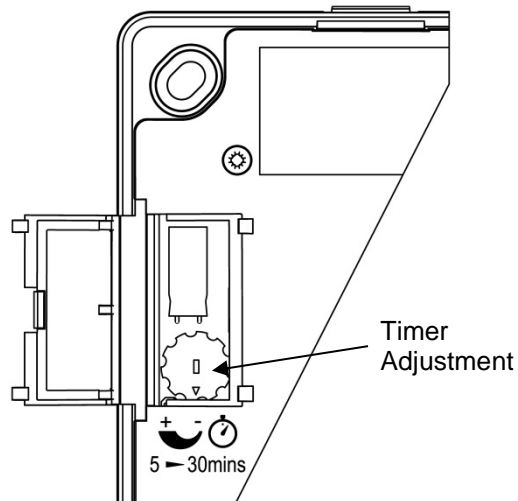

**Timer Adjustment**

To **REDUCE** the operating time, use a small screwdriver to turn the adjuster **ANTI-CLOCKWISE**.  
 To **INCREASE** the operating time, use a small screwdriver to turn the adjuster **CLOCKWISE**.



**FIG. 6: HUMIDISTAT-TIMER**

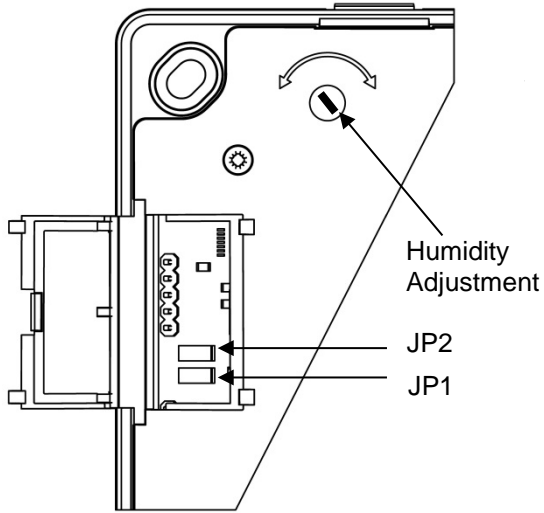

**Humidity Adjustment (25-95%RH)**

To **INCREASE SET POINT**, turn the adjuster **clockwise**. This makes the controller **LESS** sensitive.  
To **REDUCE SET POINT**, turn the adjuster **anti-clockwise**. This makes the controller **MORE** sensitive.

**Speed selection (JP2).**

The fan is factory set to low speed with jumper JP2 fitted. To activate the high speed setting remove jumper JP2.

**Timer Function (JP1)**

JP1 to deactivate the timer, remove the jumper.  
15min. timer = jumper in.  
No timer = jumper out.

**Comfort mode (On Pullcord)**

To activate the comfort mode pull and hold the pullcord for 5 Seconds. The LED will flash to indicate that comfort mode has been set.

LED will flash when Comfort Mode is active

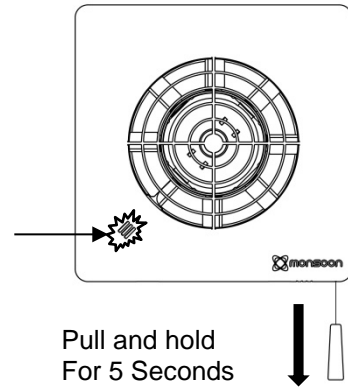







**Disposal**

This product should not be disposed of with household waste. Please recycle where facilities exist. Check with your local authority for recycling advice

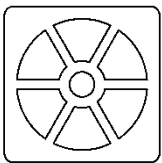

**NATIONAL  
VENTILATION**



National Ventilation  
Stathe Road  
Burrowbridge  
Somerset  
TA7 0RY

Website: [www.nationalventilation.co.uk](http://www.nationalventilation.co.uk)  
email: [info@nvagroup.co.uk](mailto:info@nvagroup.co.uk)  
Sales and technical hotline: 01823 690290

EU Authorised Representative: National Ventilation Sigarenmaker 5 - 5521DJ Eersel Nederland. [authorisedrep@nationalventilation.nl](mailto:authorisedrep@nationalventilation.nl)