

**NATIONAL  
VENTILATION**

Manufacturers & suppliers  
of  monsoon products

# Monsoon Plastic Cased Centrifugal fan

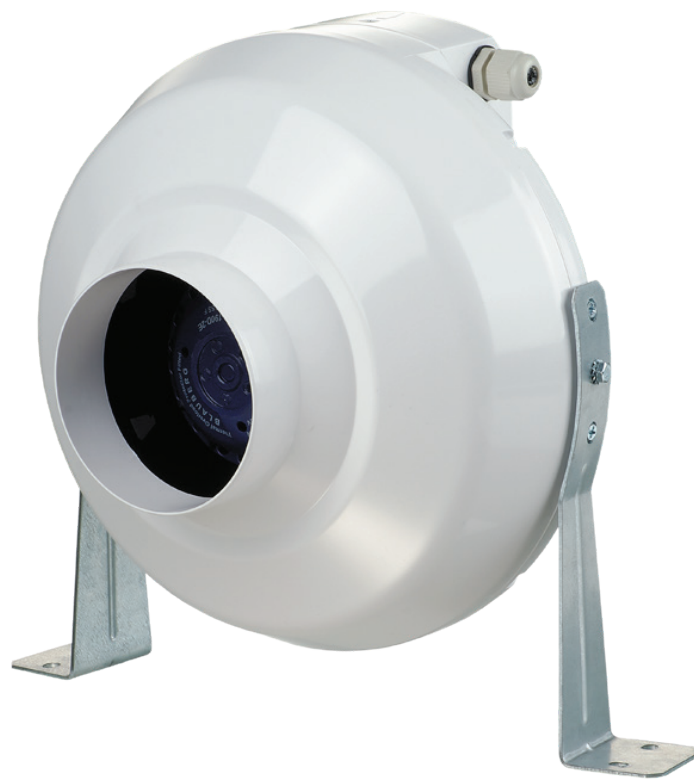

- Equipped with Standard Thermal Overload Protection (STOP)
- Complete with detachable mounting bracket
- Speed controllable, ball bearing motor
- Moisture resistant IPX4
- Suitable for long duct runs

**Call now to find out more: 01823 690 290**

[www.nationalventilation.co.uk](http://www.nationalventilation.co.uk) Email: [info@nvagroup.co.uk](mailto:info@nvagroup.co.uk)

The Monsoon Plastic Cased Centrifugal Fan from National Ventilation is applied for supply and exhaust ventilation systems of domestic applications. Due to the corrosion-resistant durable plastic casing, these models are the perfect solution for the installation in exhaust ventilation systems in humid premises such as bathrooms and kitchens.

Complete with a detachable mounting bracket, this fan can be mounted at any angle either on the wall or ceiling and with a high air capacity is also suitable for long duct runs.

### Models available

CODE	DESCRIPTION
UT100	100mm In-line Centrifugal Fan (250m <sup>3</sup> /h)
UT125	125mm In-line Centrifugal Fan (355m <sup>3</sup> /h)
UT150	150mm In-line Centrifugal Fan (460m <sup>3</sup> /h)

### Technical data

FEATURE	UT100	UT125	UT150
Volts at 50Hz (V)	230	230	230
Power (W)	80	79	80
Current (A)	0.34	0.34	0.35
Maximum air flow (m <sup>3</sup> /h)	250	355	460
Sound @ 3m dB(A)	46	46	46
Rotation speed (min-1)	2820	2800	2725
Maximum operating temperature (°C)	-25 / +55	-25 / +55	-25 / +55

### Performance

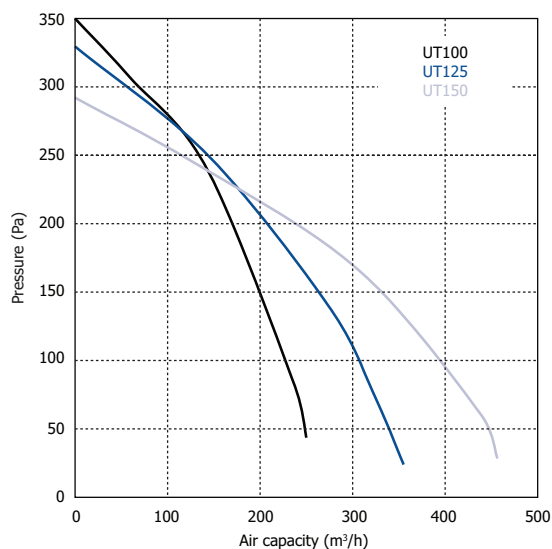

### Dimensions (mm)

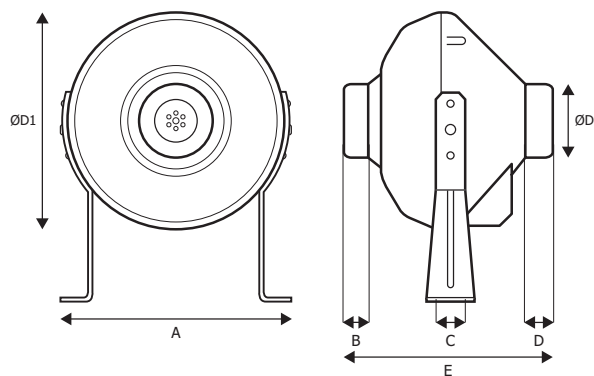

MODEL	ØD1	ØD	A	B	C	D	E
UT100	250	100	270	27	30	30	230
UT125	250	125	270	27	30	30	220
UT150	300	150	310	30	30	30	286

**Call now to find out more: 01823 690 290**

[www.nationalventilation.co.uk](http://www.nationalventilation.co.uk) Email: [info@nvagroup.co.uk](mailto:info@nvagroup.co.uk)