

**NATIONAL
VENTILATION**

Manufacturers & suppliers
of  **monsoon** products

Monsoon Energysaver™ MON-MEV DC Multi Room Unit

Continuous running mechanical extract ventilation



5YR WARRANTY



- Suitable for wall, ceiling or loft mounting
- Four 125mm extract points
- Continuous Operation
- Quiet Running
- Extract from numerous rooms

Call now to find out more: 01823 690 290

www.nationalventilation.co.uk Email: info@nvagroup.co.uk

 **MADE IN THE UK**

The Monsoon Energysaver multi-room product is a mechanical extract ventilation unit which has been designed for continuous extract of stale air from separate areas around the home or for commercial applications where a multipoint extractor system is needed, including toilets, changing rooms and cubicles. These multi-room extract units have been developed so they can be installed in many applications and condensate drains are provided where the ambient air has a high humidity content.

Models available

CODE	DESCRIPTION
MON-MEVDC400	Monsoon DC Multi-Room Unit (425 m ³ /h – 118 l/s)
MON-MEVDC/H400	Monsoon DC Multi-Room Unit built-in Humidistat (425 m ³ /h – 118 l/s)
SPIR	PIR controller
FT1	Wired Remote Timer

Technical data

	FID m ³ /h (l/s)		SOUND dB(A) @ 3m			
			CASING BREAKOUT		DUCT INLET	
	MIN	MAX	MIN	MAX	MIN	MAX
MON-MEVDC400	88 (24)	425 (118)	13	37	18	40
MON-MEV DC/H400	88 (24)	425 (118)	13	37	18	40

SAP PCDB test results

EXHAUST TERMINAL CONFIGURATION	TOTAL FLOW RATE	SFP (W/l/s)
K + 1	21	0.15
K + 2	29	0.14
K + 3	37	0.16
K + 4	45	0.18
K + 5	53	0.21
K + 6	61	0.26

Performance

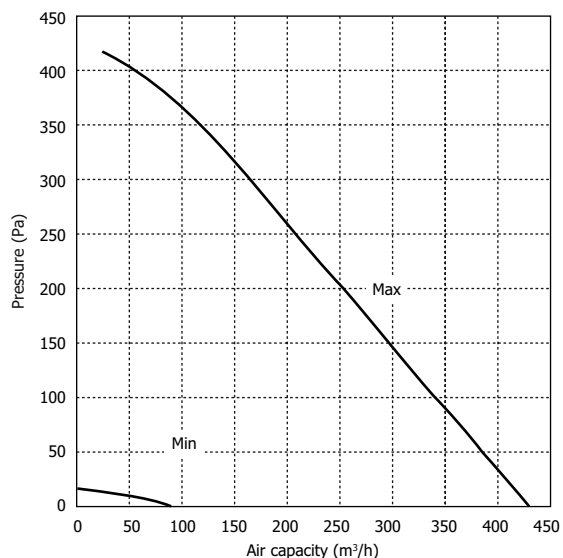

Dimensions (mm)

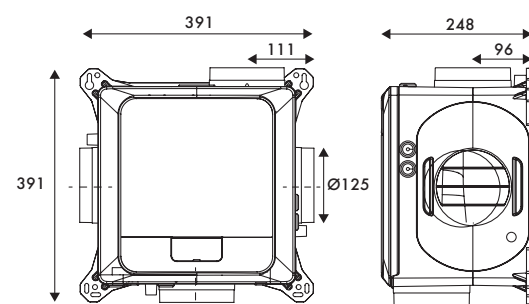

Weight: 4.1kg

Call now to find out more: 01823 690 290

www.nationalventilation.co.uk Email: info@nvagroup.co.uk

 **MADE IN THE UK**